

## High-precision Switch for Detecting Micron-unit Displacement

- Ideal for detecting and measuring wear of cutting tools or for original point of work.
- Ceramic plungers on M5, M8, and slim models for superior abrasion resistance and resistance to temperature changes.
- Direct input possible to microprocessors and programmable controllers.
- A version with screw-type cable connector available for easy installation and maintenance.

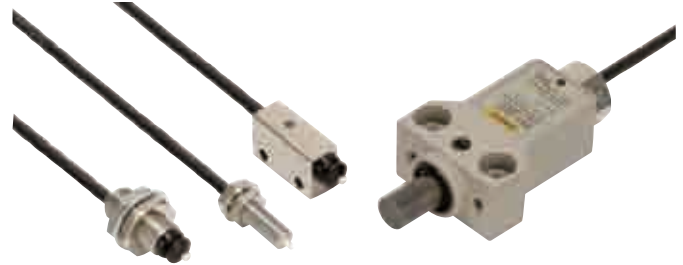

Be sure to read *Safety Precautions* on page 5 to 6 and *Safety Precautions for All Limit Switches*.

## Application Examples

### Origin Position Control of an X-Y Table

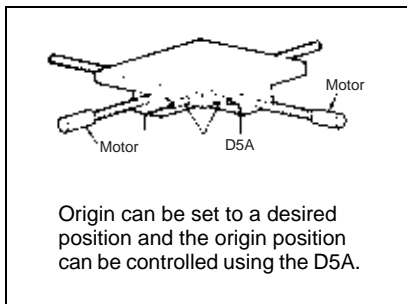

### Coaxiality Inspection

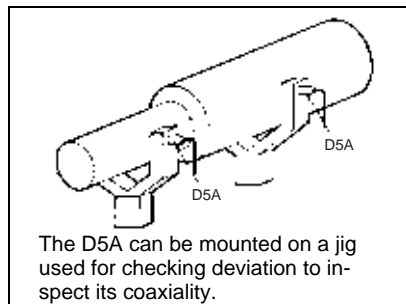

### Checking Turret Indexing Position

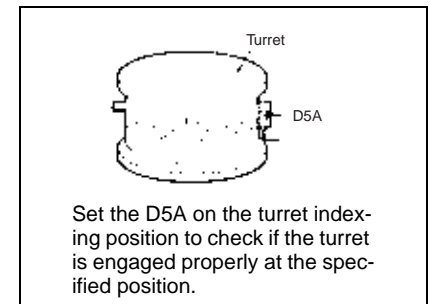



## Ordering Information

### Contact Output Models (NC Contact)

Actuator	Type	Operation Indicator	Repeat accuracy	Operating force OF max.	Cable lead outlet		Degree of protection	Model
					Lead outlet	Length		
Pin plunger 	M5	None	1 μm max.	0.29 N	Pre-wired	1 m	IP40	D5A-1100
				0.49 N				D5A-1200
			3 μm max.	0.29 N				D5A-2100
				0.49 N				D5A-2200
	M8		1 μm max.	0.49 N	IP67	D5A-3200		
			0.98 N	D5A-3300				
M16	3 μm max.	2.45 N	Connector	D5A-7400				
					D5A-7403			

### Solid-state Output Models (PNP Transistor Output)

Actuator	Type	Operation Indicator	Repeat accuracy	Operating force OF max.	Cable lead outlet		Degree of protection	Model
					Lead outlet	Length		
Pin plunger 	M8	Provided	1 μm max.	0.49 N	Pre-wired	1 m	IP67	D5A-3210
				0.98 N				D5A-3310
	Slim			0.49 N				D5A-5210
				0.98 N				D5A-5310
M16	3 μm max.		2.45 N	Connector	D5A-7410			
					D5A-7413			
Top plunger 	Limit		3 μm max.	3.92 N	Pre-wired	3 m		D5A-8511
					Pre-wired	5 m		D5A-8512
		Connector			3 m	D5A-8514		
					5 m	D5A-8515		
Bevel plunger 		Pre-wired	3 m	5 m	D5A-9511			
					Connector	3 m	D5A-9512	
						5 m	D5A-9514	
							5 m	D5A-9515

# Specifications

## Ratings

Item	Electrical ratings
Contact output models	M5, M8, M16 Type: 10 mA at 24 VAC 10 mA at 12 VDC
Solid-state output models	100 mA at 5 to 24 VDC±10% Leakage current: 0.15 mA max. Residual voltage: 3 V max. Power consumption: 3 mW max.

## Engineering Data

### Repeat Accuracy Examples (Reference Data)

#### M5 Type (Contact Output) With Repeat Accuracy of 1 μm max. D5A-1□□□ Series

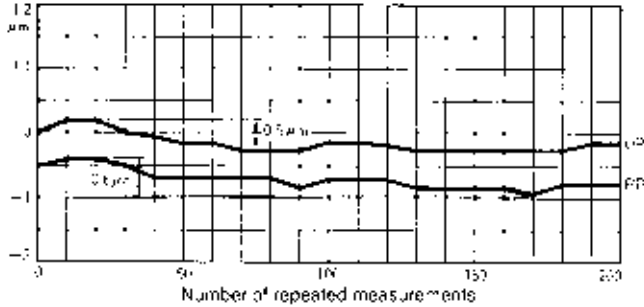

## Characteristics

Degree of protection	D5A-1□, D5A-2□: IP40 Other than the above models: IP67	
Repeat accuracy *1	M5 (D5A-1 □□□ series), M8, slim type: 1 μm max. M5 (D5A-2 □□□ series), M16, limit type: 3 μm max.	
Durability *2	Mechanical	10,000,000 operations min.
	Electrical	1,000,000 operation min. (Contact output models: 24 VAC, 10 mA, resistive load, Solid-state output models: 24 VAC, 100 mA, resistive load)
Deviation in electrical durability after 1,000,000 operations	M5, M8, M16, slim type: 10 μm max. Limit type: 20 μm max.	
Operating speed	1 μm/s to 0.5 m/s	
Rated frequency	50/60 Hz	
Insulation resistance	100 MΩ min. (at 250 VDC) between each terminal and non-current-carrying metal part	
Contact resistance (Initial value)	800 mΩ max. (initial) with 1 m cable, 2.4 Ω max. (initial) with 3 m cable, 4 Ω max. (initial) with 5 m cable	
Dielectric strength	1,000 VAC, 50/60 Hz for 1 min between each terminal and non-current-carrying metal part	
Vibration resistance	Malfunction	10 to 55 Hz, 1.5-mm double amplitude
Shock resistance	Mechanical	1,000 m/s <sup>2</sup> min.
	Malfunction	300 m/s <sup>2</sup> min.
Temperature coefficient *3	M5, M8, slim type: ±20 × 10 <sup>-6</sup> /°C max. M16 type: ±40 × 10 <sup>-6</sup> /°C max. Limit type: ±50 × 10 <sup>-6</sup> /°C max.	
Ambient operating temperature	-20°C to +75°C (with no icing)	
Ambient operating humidity	35% to 85%RH (35% to 95%RH with the seal rubber)	

Note: The above figures are initial values.

\*1. Contact your OMRON sales representative for measurement conditions of the repeat accuracy.

\*2. Durability values are calculated at an operating temperature of +5°C to +35°C, and an operating humidity of 40% to 70%RH. Contact your OMRON sales representative for more detailed information on other operating environments.

\*3. The value indicates the operating position change rate for a change of 1°C in the ambient temperature. The specifications depend on the model. Contact your OMRON sales representative for details.

## Structure and Nomenclature

### Structure

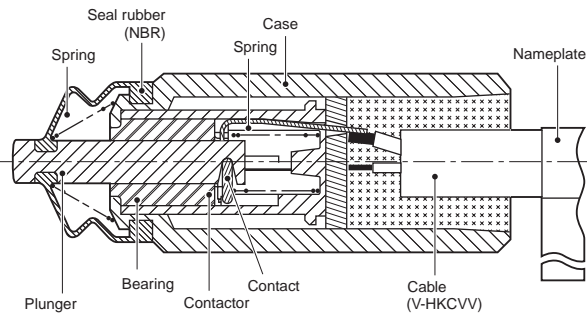

### Contact Form/Output Circuit Diagram

#### Contact Output Models

##### M5, M8, M16 type

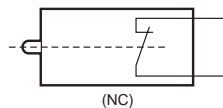

Note: NO Switches are not available with contact output models.

#### Solid-state Output Models (PNP Transistor Output)

##### M8, Slim, M16, Limit type

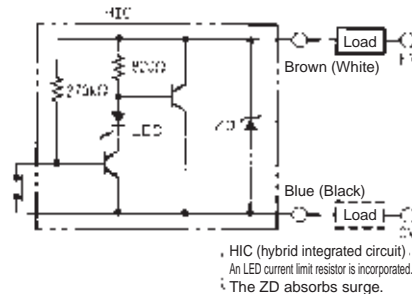

Note: The load may be connected to either the +V or 0 V terminal. Core wire colors have been changed accompanying changes in standards. The old core wire colors are given in parentheses.

Dimensions and Operating Characteristics

M5 Type (Contact Output)

D5A-1100 D5A-2100  
D5A-1200 D5A-2200

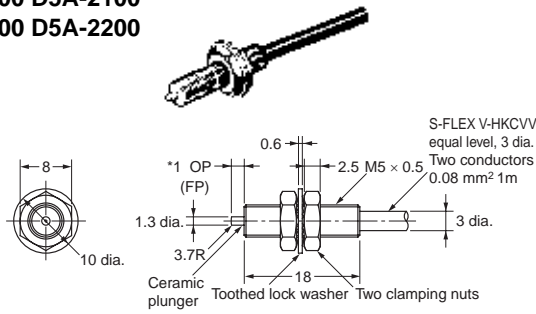

M8 Type (Solid-state Output)

D5A-3210  
D5A-3310

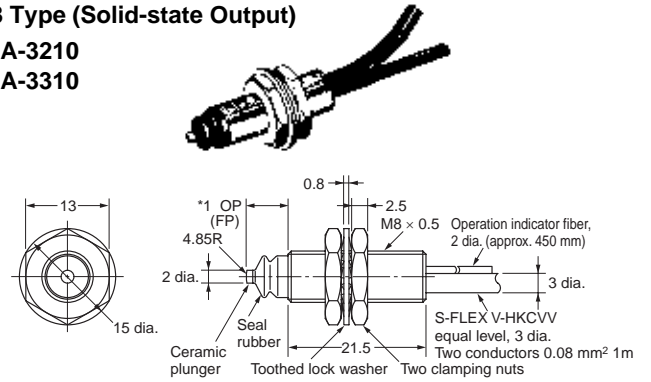

M8 Type (Contact Output)

D5A-3200  
D5A-3300

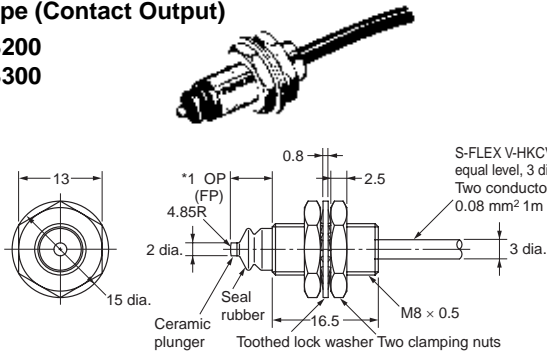

Slim Type (Solid-state Output)

D5A-5210  
D5A-5310

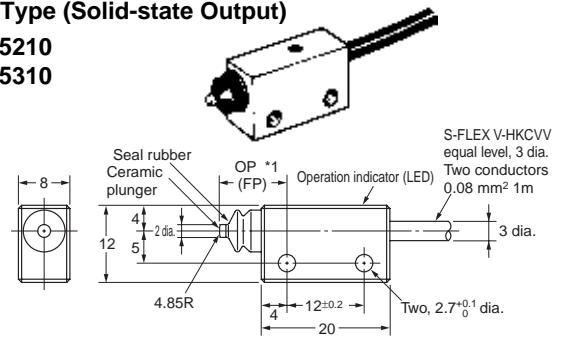

M16 Type (Contact Output/Solid-state Output)

D5A-7400  
D5A-7410

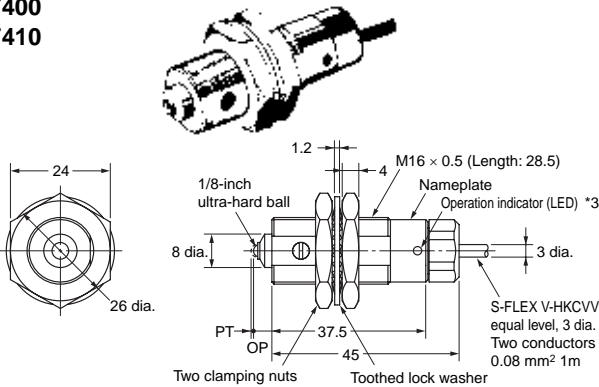

M16 Type (Contact Output/Solid-state Output)

D5A-7403  
D5A-7413  
(Connector type)

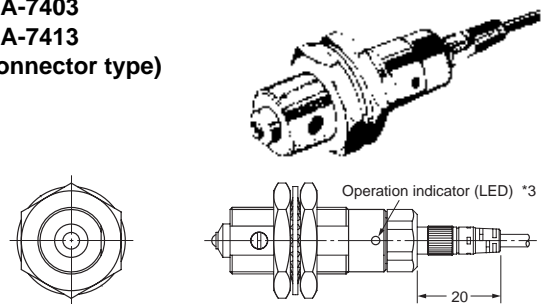

Note: 1. The dimensions are the same as the left model's.  
2. Cables with connectors are not sold separately.

Note: 1. Unless otherwise specified, a tolerance of ±0.4 mm applies to all dimensions.

2. Special screw dimensions apply to the case screws (pitch: 0.5 mm). Mounting is not possible with standard tapping. Use the provided special nuts.

Operating characteristics	Model	D5A-1100	D5A-1200	D5A-3200	D5A-3300	D5A-5210	D5A-5310	D5A-7400, D5A-7410
		D5A-2100 *2	D5A-2200 *2	D5A-3210 *2	D5A-3310 *2			D5A-7403, D5A-7413
Operating force	OF max.	0.29 N	0.49 N	0.49 N	0.98 N	0.49 N	0.98 N	2.45 N
Pretravel	PT max.	---	---	---	---	---	---	1 mm
Overtravel	OT min.	1.5 mm	1.5 mm	1.5 mm	1.5 mm	1.5 mm	1.5 mm	2 mm
Movement		5 μm	5 μm	5 μm	5 μm	5 μm	5 μm	5 μm
Differential	MD max.							
Operating Position	OP *1	(2 mm)	(2 mm)	(6.5 mm)	(6.5 mm)	10.5±0.4 mm	10.5±0.4 mm	(4.4 mm)
Free Position	FP	---	---	---	---	---	---	(5 mm)

\*1. The operating position of these types is the same as the free position because of high sensitivity (repeat accuracy: 1 μm max.). This does not apply to M16 limit switch types.

\*2. Total movement is 1.9 to 2.1 mm. Set the appropriate stroke (plunging depth) to 1.0 to 1.5 mm from the FP.

\*3. Not available in the contact output type.

**Limit Type (Solid-state Output)**

D5A-8511  
D5A-8512

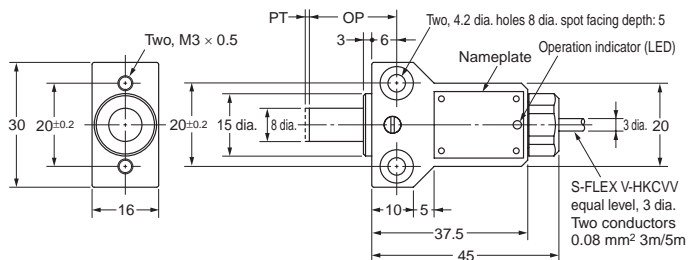

**Limit Type (Solid-state Output)**

D5A-8514  
D5A-8515  
(Connector type)

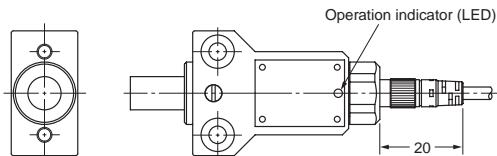

Note: 1. The dimensions are the same as the left model's.  
2. Cables with connectors are not sold separately.

**Limit Type (Solid-state Output)**

D5A-9511  
D5A-9512

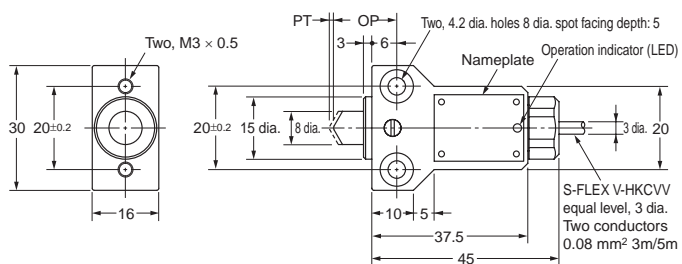
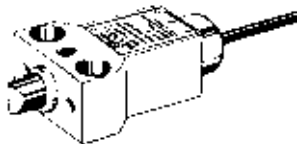

**Limit Type (Solid-state Output)**

D5A-9514  
D5A-9515  
(Connector type)

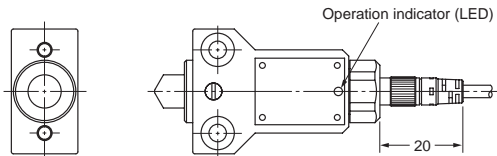
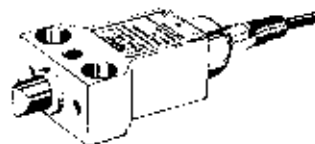

Note: 1. The dimensions are the same as the left model's.  
2. Cables with connectors are not sold separately.

Note: Unless otherwise specified, a tolerance of ±0.4 mm applies to all dimensions.

Operating characteristics	Model	D5A-8511, -8514 D5A-8512, -8515	D5A-9511, -9514 D5A-9512, -9515
Operating force	OF max.	3.93 N	3.93 N
Pretravel	PT max.	1 mm	1 mm
Overtravel	OT min.	5 mm	4 mm
Movement Differential	MD max.	5 μm	5 μm
Operating Position	OP	21.0±0.4 mm (21.8mm)	15.2±0.4 mm (15.8mm)
Free Position	FP		

## Safety Precautions

Refer to *Safety Precautions for All Limit Switches*.

### Precautions for Correct Use

#### Handling of Fiber Cable

- Do not pull or impose any force exceeding 29.42 N on the fiber cable.
- Make sure that the bending radius of the fiber cable is as large as possible and at least R20 mm.
- The 40-mm portion of the fiber cable on the connector end as shown below must not be bent.

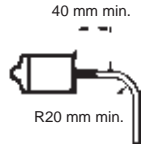

- Do not impose compressing loads on the fiber cable.

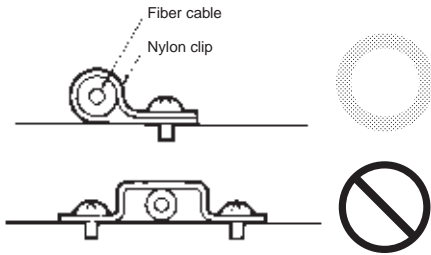

- The fiber cable can be cut with OMRON's E39-F4 Cutting Tool.
- Do not impose any force exceeding 29.42 N on the cable, otherwise the cord may break. Make sure that the bending radius of the cable is at least 20 mm.

#### Mounting

- The screw sections of cases for M5, M8, and M16 types have special dimensions. Do not use the mounting dimensions specified for standard types.
- For the mounting dimensions, refer to the following figures and tables.

Type	M5	M8		M16
		Contact output	Solid-state output	
A (Mounting hole)	5.2±0.1 mm dia.	8.2±0.1 mm dia.		16.2±0.1 mm dia.
B (Panel thickness)	3 to 10 mm	5 to 8 mm	5 to 13 mm	10 to 17 mm
C (Toothed lock washer)	10 mm dia.	15 mm dia.		26 mm dia.

Size	Type	Slim	Limit
		A	Mounting pitch
B	Tapping	M2.6	M4
	Mounting hole	2.8 <sup>+0.2</sup> / <sub>0</sub> mm dia.	4.2 <sup>+0.2</sup> / <sub>0</sub> mm dia.

- Do not tighten the nut with too much force. Be sure to apply the torque shown in this table.

Type	Appropriate tightening torque
M5	0.98 N·m max.
M8	2.94 N·m max.
M16	9.81 N·m max.
Slim	0.29 N·m max. (M2.6 screw)
Limit	1.47 N·m max. (M4 screw)

- When mounting the Switch to a panel, be sure to use the toothed lock washer attached as an accessory (to M5, M8, and M16 types only). Use the washer on the panel surface opposite the object to be detected by the Switch.

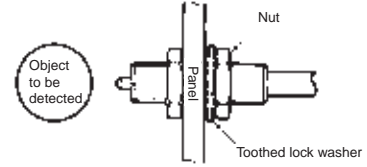

#### Connection of Contact Output

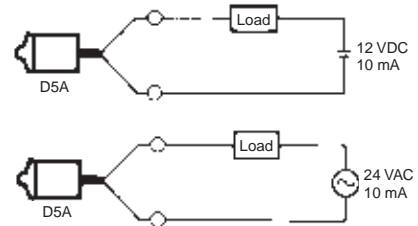

Consideration of polarity is not required.

#### Connection of Solid-state Output

- Be sure to connect the load to the power source in series.
- The operating state of the Switch can be checked by the LED operation indicator (lights when the Switch is in operation) incorporated in the solid-state output circuit.
- The output residual voltage is approximately 3 V. Therefore, exercise care when selecting the load and setting the supply voltage. The residual voltage, however, can be easily calculated because it is almost constant and is free from the influence of fluctuation in the load current.

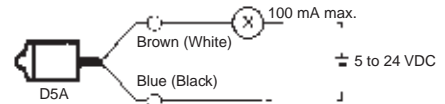

Note: The lead wire colors of the D5A have been changed in compliance with the latest applicable JIS standards. Colors in parentheses are previous ones.

[Example]

- In the above circuit, suppose the MY relay rated at 12 VDC is used as the load. Since the must operate voltage of the relay is 80% or less than the rated voltage, it is  $12 \times 0.8 = 9.6$  V. The supply voltage, in turn, is  $3 + 9.6 = 12.6$  V. Therefore, the relay may not operate with a 12 V power source.
- However, if the relay rated at 24 VDC is employed, the must operate voltage and supply voltage of the relay are respectively 19.2 V and 22.2 V. The relay therefore can operate with a 24 V power source.

- When a solid-state circuit is turned OFF, leakage current of 0.15 mA (max.) flows, causing some voltages to remain in the load. For this reason, be sure to check the must release voltage of the load before using it.

## Series Connection of Switches

The Solid-state Output-type Switches must not be connected in series. To obtain the same effect as a series connection, form an AND gate with a relay inserted between the Switch and load.

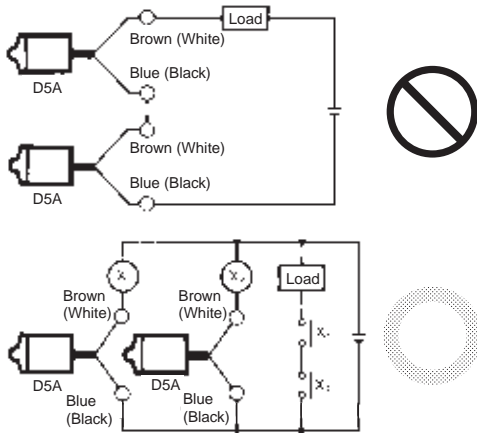

## Parallel Connection of Switches

- In principle, two or more D5A's should not be used in an OR configuration.

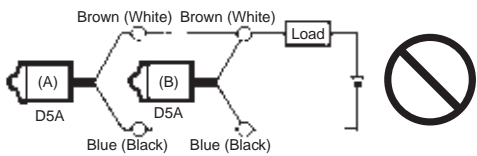

- However, they can be connected in parallel provided that both switches A and B in the above figure do not operate at the same time and that the load does not have to be kept energized. In this circuit, however, the leakage current is increased, multiplied by the number of switches connected in parallel. Consequently, the Switch may not release properly. To keep the load energized, connect a relay to each of the Switches as shown below.

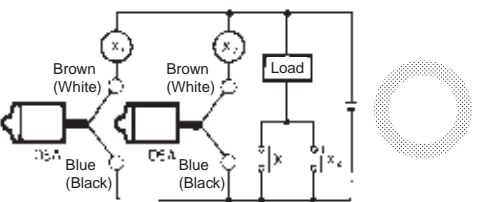

## Connection to Power Source

- Be sure to connect the Switch to the power source via the load. If directly connected to the power source, the internal elements of the Switch may be damaged.

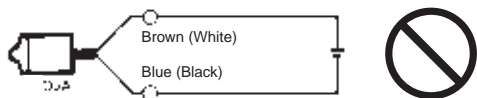

- Correctly connect the white and black lead wires to the positive and negative sides, respectively, of the power source. Although the D5A will not be damaged even if the polarity is reversed by mistake, if this happens, the Switch maintains the ON state (i.e., the contact is kept open) regardless of the presence or absence of the object to be detected.

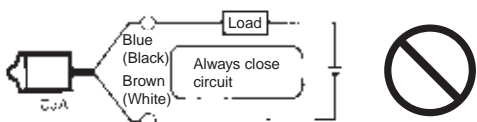

The core wire colors have been changed to meet new standards. Make sure that the wires are connected correctly.

## Others

- Adjust the mounting of the D5A until the stroke of the pin plunger and top plunger is aligned with the stroke of the operating body. Special attention should be paid to the ceramic pushbutton unit. It might be damaged if undue shock is applied.

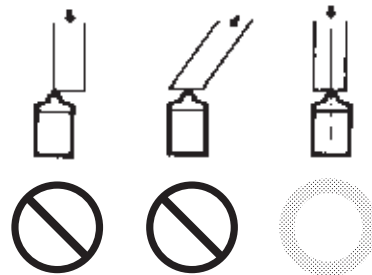

- The harder the material for the dog and the more solidly the mounting base is fitted, the more accurately a minute displacement is detected.
- When a limit switch type (D5A-8 □□□, D5A-9 □□□) is used, apply grease to the dog to reduce friction between it and the plunger. **Do not apply grease to pin plungers, otherwise the grease may stick to the contacts or generate gas that may cause contact failures.**
- Be sure to use dogs made of hard materials for bevel or top plungers and apply grease to the surface of the dogs. The hardness (Hv) of a bevel plunger is 2,000 or over, for which it is recommended that a dog that has an Hv value of 1,000 or less be used.
- Do not fail to provide a stopper so as to prevent the enclosure of the D5A from being used as the stoppers.

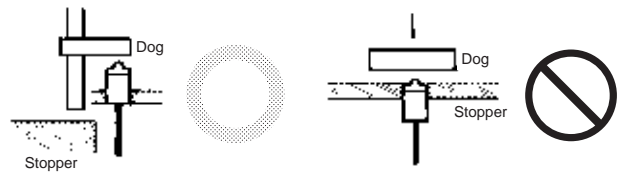

- Attach an appropriate cover for the protection of the D5A from machining oil or cuttings. No protective cover is, however, provided together with the Switch.
- Exercise care that excessive force is not applied to the ceramic plunger of M5, M8, or slim type. If the possibility exists that strong shock may be applied to the plunger when the Switch is being mounted, use a protective cap. The plunger may not release if it is depressed with too great a force. Set its stroke by referring to the OT value indicated in Operating Characteristics.

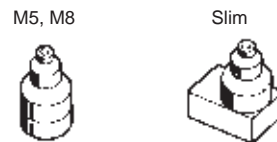

- Do not mount the Switch with its nameplate facing downwards (i.e., in the direction of gravity), otherwise the oil drain hole will not work effectively.

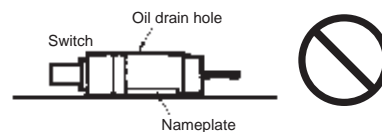



**ASH & ALAIN**

**Authorised Distributors:-**

**ASH & ALAIN INDIA PVT LTD**

S-100, F.I.E.E., Okhla Industrial Area, Phase-ii, New Delhi-110020(India)

Tel : 011-43797575 Fax : 011-43797574 E-mail : [sales@ashalain.com](mailto:sales@ashalain.com)